

Model for collisions in granular gases

Nikolai V. Brilliantov*

Moscow State University, Physics Department, Moscow 119 899, Russia

Frank Spahn and Jan-Martin Hertzsch

University Potsdam, Am Neuen Palais, D-14 415 Potsdam, Germany

Thorsten Pöschel†

Institut für Physik, Humboldt-Universität zu Berlin, Invalidenstraße 110, D-10115 Berlin, Germany

(Received 8 September 1994; revised manuscript received 27 February 1995)

We propose a model for collisions between particles of a granular material and calculate the restitution coefficients for the normal and tangential motion as functions of the impact velocity from considerations of dissipative viscoelastic collisions. Existing models of impact with dissipation as well as the classical Hertz impact theory are included in the present model as special cases. We find that the type of collision (smooth, reflecting or sticky) is determined by the impact velocity and by the surface properties of the colliding grains. We observe a rather nontrivial dependence of the tangential restitution coefficient on the impact velocity.

PACS number(s): 46.10.+z, 51.10.+y, 62.20.Fe, 83.70.Fn

I. INTRODUCTION

A rich variety of systems one encounters in nature may be considered as “granular gas” [1]. The most important difference between a “gas” of granular particles and a regular gas is the inelastic nature of the interparticle collisions. The steady removal of kinetic energy from the granular gas due to dissipative collisions causes a variety of nonequilibrium processes that have been subjects of experimental (e.g., [2–10]) and theoretical (e.g., [11–15]) interest. Particularly in recent time many of the experimental results have been reproduced and investigated using various techniques such as cellular automata (e.g., [16–18]), Monte Carlo methods [19], lattice-gas models [20], and molecular dynamics in two [21–24] and three [25–27] dimensions and hybrid methods [28–31].

The loss of kinetic energy of a pair of inelastically colliding grains can be described using the restitution coefficients for the normal and tangential components of the relative motion ϵ^N and ϵ^T

$$(\vec{g}^N)' = -\epsilon^N \vec{g}^N \quad (0 \leq \epsilon^N \leq 1), \quad (1a)$$

$$(\vec{g}^T)' = \epsilon^T \vec{g}^T \quad (-1 \leq \epsilon^T \leq 1), \quad (1b)$$

where \vec{g}^N and \vec{g}^T are the relative velocities of the particles in normal and tangential directions before the collision and $(\vec{g}^N)'$, $(\vec{g}^T)'$ after the collision.

Recently, the collision properties of small spheres have been investigated experimentally [32]. These investigations

have shown that the type of the collision (sliding or sticking) depends on the ratio of g^N and g^T . The results were explained with different models for each type, and the coefficients in these models were independent of the velocity. On the other hand, laboratory experiments with ice balls [33] as well as with spheres of other materials (for an overview see [34]) have shown that the normal restitution coefficient ϵ^N depends significantly on the impact velocity. As already seen, the tangential restitution coefficient depends on the impact parameters as well.

The behavior of the sheared granular material may be significantly different if the restitution coefficients depend on the impact velocity. This dependence should be taken into account in order to get an adequate model of the stress distribution [35]. It is also known that the parameters ϵ^N and ϵ^T crucially influence the global dynamics of granular systems (e.g., [36,37]).

In the present study we investigate how the restitution coefficients depend on the relative impact velocity. For the normal component of the relative motion we derive an expression for the normal force acting between the colliding particles, which accounts for the dissipation in the bulk of material. One particular application of the results presented here is the explanation of experiments with ice balls [33], which are of importance for the investigation of the dynamics of planetary rings [38]. A static model for the inelastic impact of metal bodies was presented in [39], which is based on the assumption of fully plastic indentation and constant mean contact pressure and leads analytically to a proportionality $\epsilon^N \propto (g^N)^{-1/4}$ for arbitrary material constants. On the contrary, our quasistatic approach does not request other additional assumptions and can be adapted to different experimental results by changing the coefficients in the differential equation that describes the time dependence of the deformation. From these coefficients, material coefficients can be estimated [40].

Our result contains the Hertz theory of elastic impact [41] and the theory of the viscoelastic impact by Pao [42] as

* Also at Universität Potsdam, Am Neuen Palais, D-14 415, Potsdam, Germany.

† Also at The James Franck Institute, The University of Chicago, 5640 South Ellis Ave., Chicago, IL 60 637. Electronic address: thorsten@hlrsun.hlrz.kfa-juelich.de
http://summa.physik.hu-berlin.de:80/thorsten/

special cases. For the tangential component of the relative motion we consider a mesoscopic model of the contact of colliding particles. We derive a mean-field expression for the tangential interparticle force. The result contains the model of the tangential force of colliding particles by Haff and Werner [43,44] as a special case, and we are able to treat different tangential collisional behaviors within the framework of one single model.

In Sec. II we formulate the collision model and derive the equations for the normal and tangential components of the relative motion of the colliding grains. In Sec. III we present the results for the restitution coefficients for the proposed model and discuss the dependence of the coefficients on the components of the impact velocity. A model for the dynamics of granular materials is proposed. In Sec. IV we summarize the results. Details of the derivations are given in Appendices A and B.

II. THE COLLISION MODEL

We consider the inelastic collision between two spherical particles i and j . The values \vec{r}_i , R_i , $\dot{\vec{r}}_i$, $\vec{\omega}_i$, m_i , and J_i are the position of the center of sphere i , its radius, velocity, angular velocity, mass, and moment of inertia, respectively. The relative velocity of the surfaces of the colliding particles at the point of contact is given by (e.g., [43,34])

$$\begin{aligned}\vec{g}_{ij} &= (\dot{\vec{r}}_i - \vec{\omega}_i \times R_i \vec{n}) - (\dot{\vec{r}}_j + \vec{\omega}_j \times R_j \vec{n}) \\ &= \dot{\vec{r}}_i - \dot{\vec{r}}_j - R_i \vec{\omega}_i \times \vec{n} - R_j \vec{\omega}_j \times \vec{n},\end{aligned}\quad (2)$$

with $\vec{n} = (\vec{r}_i - \vec{r}_j) / |\vec{r}_i - \vec{r}_j|$. Introducing the dimensionless moment of inertia \hat{J}_i , the effective mass m_{ij}^{eff} and the effective radius R_{ij}^{eff}

$$\hat{J}_i = \frac{J_i}{m_i R_i^2}, \quad (3a)$$

$$m_{ij}^{\text{eff}} = \frac{m_i m_j}{m_i + m_j}, \quad (3b)$$

$$R_{ij}^{\text{eff}} = \frac{R_i R_j}{R_i + R_j}, \quad (3c)$$

one obtains Newtons equations for the translational and rotational motion

$$\frac{d\vec{g}_{ij}}{dt} = \frac{\vec{F}_{ij}}{m_{ij}^{\text{eff}}} + \left(\frac{1}{\hat{J}_i m_i} + \frac{1}{\hat{J}_j m_j} \right) (\vec{n} \times \vec{F}_{ij}) \times \vec{n}. \quad (4)$$

The force \vec{F}_{ij} acting between the particles during collision consists of the normal component $\vec{F}_{ij}^N = \vec{n}(\vec{n} \cdot \vec{F}_{ij})$ and the tangential component $\vec{F}_{ij}^T = \vec{F}_{ij} - \vec{F}_{ij}^N$. Introducing the corresponding components \vec{g}_{ij}^N and \vec{g}_{ij}^T of the relative velocity \vec{g}_{ij} and with

$$\kappa_{ij}^{-1} = 1 + \frac{m_i \hat{J}_i + m_j \hat{J}_j}{\hat{J}_i \hat{J}_j (m_i + m_j)} \quad (5)$$

we rewrite Eq. (4) omitting the indexes ij :

$$\dot{\vec{g}}^N = \vec{F}^N / m^{\text{eff}}, \quad (6a)$$

$$\dot{\vec{g}}^T = \frac{1}{m^{\text{eff}} \kappa} \vec{F}^T. \quad (6b)$$

Using Eqs. (1) the energy loss during the collision is

$$\Delta Q = \frac{m^{\text{eff}}}{2} (\vec{g}^N)^2 [(\epsilon^N)^2 - 1] + \frac{m^{\text{eff}}}{2} \kappa (\vec{g}^T)^2 [(\epsilon^T)^2 - 1]. \quad (7)$$

The energy is conserved during the collision if $\epsilon^N = 1$ and $\epsilon^T = \pm 1$. In these cases there is a completely elastic rebound for the normal component and either completely elastic rebound (rough spheres) or frictionless slipping (smooth spheres) for the tangential component.

A. Normal motion

We assume that the colliding particles begin to touch each other at the time $t=0$ with the relative normal velocity \vec{g}^N . When we introduce the deformation (or ‘‘compression’’)

$$\xi(t) = R_i + R_j - [|\vec{r}_i(t) - \vec{r}_j(t)|] \quad (8)$$

this velocity can be written as $g^N = |\vec{g}^N| = \dot{\xi}$.

Thus from Eq. (6a) we obtain the equations

$$\begin{aligned}\ddot{\xi}(t) &= F^N[\xi(t)] / m^{\text{eff}}, \\ \dot{\xi}(0) &= g^N, \\ \xi(0) &= 0.\end{aligned}\quad (9)$$

The normal force F^N consists of an elastic, conservative part due to the deformation ξ of the particles and a viscous part due to dissipation of energy in the bulk of the particle material, depending on the deformation rate $\dot{\xi}$. For the conservative part Hertz’s theory of elastic contact [41] gives for spherical particles

$$F_{(\text{el})}^N(\xi) = \frac{2Y}{3(1-\nu^2)} \sqrt{R^{\text{eff}}} \xi^{3/2}, \quad (10)$$

where Y and ν are the Young modulus and the Poisson ratio for the material the particles consist of. This relation between the elastic component of the force and the deformation is valid for the quasistatic regime of the collision, i.e., when inertial and relaxation effects may be neglected (see Appendix B).

The existing phenomenological expressions for the dissipative part of the normal force, which are either linear in the deformation rate $\dot{\xi}$ (e.g., [43,45]) or quadratic [46], however, do not agree satisfactory with the experimental data for the normal restitution coefficient [33]. Pao [42] extended the Hertz theory of impact for the viscoelastic case, where, however, the dependence of the bulk dissipation on the dilatation rate was neglected. In this theory memory effects in the dissipative processes were taken into account. Although the latter approach is not self-consistent (see Appendix B), it predicts a power-law dependence of the dissipative force on the deformation rate, yielding an exponent similar to that for the

quasistatic collision. In the present study we develop a self-consistent quasistatic approximation to calculate the normal force acting between colliding viscoelastic particles. The quasistatic approximation is valid when the characteristic relative velocity of the granular particles is much less than the speed of sound in the material which is satisfied for many experimental situations even in astrophysical systems such as planetary rings [47]. For the duration of the collision it is necessary to exceed significantly the viscous memory time in the material of colliding particles (see Appendix B).

Different from the approaches of [34,42] we take into account both components of the dissipative force, arising from the shear strain rate as well as from the dilatation rate, which are both of comparable importance for the normal component of the relative motion. From the equation of motion for the viscoelastic continuum we find the general relation between the dissipative part of the normal force and the deformation rate. We show that memory effects in dissipative processes may be neglected in the case of a self-consistent quasistatic approximation. Since the calculation of the dissipative part of the normal force is rather straightforward, we present only the main idea of the derivation and refer to Appendix A for further details. In Appendix B the conditions for the validity of the quasistatic approach are given.

The total normal force acting between viscoelastic particles may be derived from a stress tensor combined of an elastic and a dissipative part [48]

$$\hat{\sigma} = \hat{\sigma}_{(\text{el})} + \hat{\sigma}_{(\text{dis})} \quad (11)$$

with

$$\hat{\sigma}_{(\text{el})} = E_1 \left[\frac{1}{2} \{ \vec{\nabla} \circ \vec{u} + \vec{u} \circ \vec{\nabla} \} - \frac{1}{3} \hat{I} \vec{\nabla} \cdot \vec{u} \right] + E_2 \hat{I} \vec{\nabla} \cdot \vec{u}, \quad (12a)$$

$$\hat{\sigma}_{(\text{dis})} = \eta_1 \left[\frac{1}{2} \{ \vec{\nabla} \circ \dot{\vec{u}} + \dot{\vec{u}} \circ \vec{\nabla} \} - \frac{1}{3} \hat{I} \vec{\nabla} \cdot \dot{\vec{u}} \right] + \eta_2 \hat{I} \vec{\nabla} \cdot \dot{\vec{u}}. \quad (12b)$$

The displacements in the material are denoted by \vec{u} and \hat{I} is the unit tensor. $E_{1/2}$ and $\eta_{1/2}$ are the elastic and the viscous constants of the particle material

$$E_1 = \frac{Y}{1 + \nu}, \quad (13a)$$

$$E_2 = \frac{Y}{3(1 - 2\nu)}. \quad (13b)$$

In the quasistatic regime the displacement field $\vec{u}(\vec{r}, t)$ can be approximated by that of the static problem $\vec{u}(\vec{r})$. It is completely determined by the elastic component of the interparticle force (10). Thus, the displacement velocities can be written as

$$\dot{\vec{u}}(\vec{r}, t) \approx \dot{\xi} \frac{\partial}{\partial \xi} \vec{u}_{(\text{el})}(\vec{r}, \xi), \quad (14)$$

where $\vec{u}_{(\text{el})}(\vec{r}, \xi)$ is the solution of the static (elastic) contact problem. This expression depends parametrically on the deformation ξ and the dissipative part of the stress tensor becomes

$$\hat{\sigma}_{(\text{dis})} = \dot{\xi} \frac{\partial}{\partial \xi} \left\{ \eta_1 \left[\frac{1}{2} (\vec{\nabla} \circ \vec{u}_{(\text{el})} + \vec{u}_{(\text{el})} \circ \vec{\nabla}) - \frac{1}{3} \hat{I} \vec{\nabla} \cdot \vec{u}_{(\text{el})} \right] + \eta_2 \hat{I} \vec{\nabla} \cdot \vec{u}_{(\text{el})} \right\}. \quad (15)$$

The calculations can be significantly simplified when we notice that the elastic and the dissipative parts of the stress tensor are related in the quasistatic regime [see Eqs. (12) and (14)]:

$$\sigma_{(\text{dis})} = \dot{\xi} \frac{\partial}{\partial \xi} \sigma_{(\text{el})} \quad (E_1 \leftrightarrow \eta_1, E_2 \leftrightarrow \eta_2). \quad (16)$$

Therefore the impact problem for the viscoelastic particles in the quasistatic regime can be mapped onto the corresponding problem for elastic particles. Performing calculations similar to that of the elastic case (for details see [49] and Appendix A) one can find an expression for the dissipative part of the normal force:

$$F_{(\text{dis})}^N = \frac{Y}{(1 - \nu^2)} \sqrt{R^{\text{eff}}} A \sqrt{\xi} \dot{\xi} \\ A = \frac{1}{3} \frac{(3\eta_2 - \eta_1)^2}{(3\eta_2 + 2\eta_1)} \left[\frac{(1 - \nu^2)(1 - 2\nu)}{Y\nu^2} \right]. \quad (17)$$

From Eqs. (17) and (10) we obtain for the normal component of the relative motion

$$\ddot{\xi} + \frac{2Y\sqrt{R^{\text{eff}}}}{3m^{\text{eff}}(1 - \nu^2)} \left(\xi^{3/2} + \frac{3}{2} A \sqrt{\xi} \dot{\xi} \right) = 0 \quad (18)$$

with the initial conditions $\dot{\xi}(0) = g^N$, $\xi(0) = 0$. In the case of $A\dot{\xi} \ll \xi$, Eq. (18) results from a Taylor expansion of

$$\ddot{\xi} + \frac{2Y\sqrt{R^{\text{eff}}}}{3m^{\text{eff}}(1 - \nu^2)} (\xi + A\dot{\xi})^{3/2} = 0, \quad (19)$$

which formally coincides with the corresponding equation for the elastic problem, provided that ξ is substituted by $\xi + A\dot{\xi}$.

It has to be noted that ξ has its minimum at the beginning of the collision where $\dot{\xi}$ takes its maximum. Hence, the condition $A\dot{\xi} \ll \xi$ is not provided at the very beginning of the contact. On the other hand, the good confirmation of experimental facts [33] by the numerical solution of Eq. (19) points to its suitability for at least the rest of the collision time span.

Taking into account $(\dot{g}^N)' = \dot{\xi}(t_c)$ (t_c is the duration of the collision), the normal restitution coefficient is obtained from

$$\epsilon^N = \dot{\xi}(t_c) / \dot{\xi}(0). \quad (20)$$

B. Tangential motion

In the idealized model the surface of contact between the spheres S is a perfectly flat circular area with radius $R_S = \sqrt{2R^{\text{eff}}\xi(t)}$. For the description of the tangential forces between the surfaces we follow a current model of tribology (e.g., [50,51]) where the apparent surface of contact is built

up of a large number of hierarchically ordered asperities varying in shape and size by several decades. For the processes of the momentum transmission we will take into account only the largest-scale asperities (“primary asperities”). The surface asperities do not affect the normal motion, if they are small enough (see Appendix A), however, they are responsible for the tangential forces, acting between the colliders. Here we consider a simplified mean-field approach and introduce the normal $\bar{\sigma}^N$ and tangential stress σ^{-T} averaged over the contact area. Further we define the normal component of the total contact area of the asperities of both spheres S^N , which is responsible for the transmission of the normal force. Correspondingly the tangential projection of the area S^T is responsible for the transmission of the tangential force. These surfaces are related to the apparent contact area by the relations [52]

$$S^N(t) = f^N(\bar{\sigma}^N)S(t), \quad (21a)$$

$$S^T(t) = f^T(\bar{\sigma}^N)S(t), \quad (21b)$$

where the coefficients f^N and f^T depend on the average normal stress $\bar{\sigma}^N$. When the spheres begin to touch each other, i.e., $S=0$ and $\bar{\sigma}^N=0$, we find $f^N(0)=0$ and $f^T(0)=0$. We expand the coefficients in Eq. (21b) with respect to $\bar{\sigma}^N=0$. The linear expansion yields for the tangential component of the surface

$$S^T(t) = \phi^T \bar{\sigma}^N S(t), \quad \phi^T = \left[\frac{\partial f^T}{\partial \bar{\sigma}^N} \right]_{\bar{\sigma}^N=0}. \quad (22)$$

For a given model of the sizes and shapes of the asperities one can calculate the value of ϕ^T [52]. In the case that the heights of the asperities obey a Gaussian probability distribution with mean value L one finds

$$\phi^T \propto \sqrt{L}. \quad (23)$$

For the average size of the asperities L of the surfaces the mean-field approach yields the average shear deformation $\eta^- = b \zeta / L$. The values ζ and b are the relative tangential

shift of the particle surfaces and a form factor, respectively. We assume that the stress is uniformly distributed over the entire surface and find

$$\sigma^{-T} = \frac{Y}{1+\nu} \bar{\eta} = \frac{Y\zeta}{(1+\nu)L} b. \quad (24)$$

The linear relation between $\bar{\sigma}^T$ and $\bar{\eta}$ holds only for the elastic regime, i.e., only if $\bar{\sigma}^T$ does not exceed some critical value σ_*^T , which is a specific material constant. If the shear stress exceeds this threshold σ_*^T , the asperity that hinders the tangential relative motion of the surfaces is assumed to break, resulting in a sudden release of the shear stress. At the same time the surfaces are shifted macroscopically with respect to each other by

$$\zeta_0 = \frac{L(1+\nu)}{bY} \sigma_*^T, \quad (25)$$

and one finds

$$\eta^-(\zeta) = \eta_* \left(\frac{\zeta}{\zeta_0} - \left\lfloor \frac{\zeta}{\zeta_0} \right\rfloor \right), \quad (26)$$

$$\eta_* = \frac{b\zeta_0}{L},$$

where $[x]$ denotes the integer of x . The breaking of the asperities dissipates the energy that was previously stored in the elastic stress; i.e., fracturing of the asperities is the elementary dissipative process in the tangential motion. From Eq. (26) we obtain the shear stress as a function of the tangential displacement

$$\sigma^{-T}(\zeta) = \sigma_*^T \left(\frac{\zeta}{\zeta_0} - \left\lfloor \frac{\zeta}{\zeta_0} \right\rfloor \right) \quad (27)$$

and the tangential component of the interparticle force

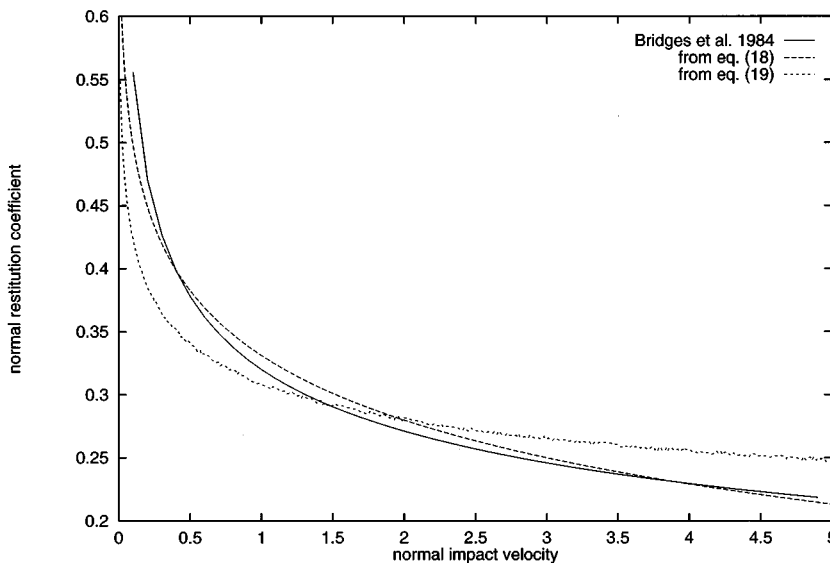

FIG. 1. The normal restitution coefficient ϵ^N vs the normal component of the impact velocity g^N measured in cm s^{-1} according to Eqs. (18) and (19). The dashed line denotes the dependence $\epsilon^N(g^N)$ measured by Bridges, Hatzes, and Lin [33].

$$\begin{aligned}
F^T &= -S^T \bar{\sigma}^T(\zeta) = -\phi^T \bar{\sigma}^N S \sigma_*^T \left(\frac{\zeta}{\zeta_0} - \left| \frac{\zeta}{\zeta_0} \right| \right) \\
&= -\mu F^N \left(\left| \frac{\zeta}{\zeta_0} - \frac{\zeta}{\zeta_0} \right| \right), \tag{28}
\end{aligned}$$

where $F^N = \bar{\sigma}^N S$ is the normal component of the interparticle force and $\mu = \phi^T \sigma_*^T$.

It may be shown that a more refined mean-field approach, which does not use the assumption of the uniformly distributed stress over the contact area, leads to the same Eq. (28) for the tangential motion.

From Eq. (28) follows the condition for the maximum tangential force:

$$F_{\max}^T = \mu F^N. \tag{29}$$

Thus our model reproduces the Coulomb friction law [53] with the friction coefficient μ expressed in terms of mesoscopic parameters. The model for the tangential motion is very similar to the extensively investigated one-dimensional model by Burridge and Knopoff [54,55] intended to model earthquakes.

With $g^T(t) = \dot{\zeta}(t)$, Eq. (5) and $F^N = -m^{\text{eff}} \ddot{\zeta}(t)$ the tangential motion is governed by the differential equation

$$\ddot{\zeta} - \frac{\mu}{\kappa} \ddot{\xi}(t) \left(\frac{\zeta}{\zeta_0} - \left| \frac{\zeta}{\zeta_0} \right| \right) = 0, \tag{30}$$

with the initial conditions $\dot{\zeta}(0) = g^T$ and $\zeta(0) = 0$. The value of $\ddot{\xi}(t)$ is given by Eq. (18) or (19). Then the tangential restitution coefficient reads

$$\epsilon^T = \dot{\zeta}(t_c) / \dot{\zeta}(0). \tag{31}$$

III. RESULTS AND DISCUSSION

The obtained equations for the normal [Eqs. (19) and (18)] and tangential motion [Eq. (30)] have been solved numerically using a Runge-Kutta method of fourth order with adaptive step size [56]. The restitution coefficients ϵ^T and ϵ^N have been calculated as functions of the normal and tangential relative velocities g^T , g^N . For the integration we used the parameters of ice at low temperatures [57]: Young modulus $Y = 10$ GPa, Poisson ratio $\nu = 0.3$, particle size $R = 10^{-2}$ m, with density $\rho = 10^3$ kg m $^{-3}$. The coefficient A in Eq. (18) was considered to be a fit parameter, due to lack of information about the dissipative coefficients η_1 and η_2 . Figure 1 shows the numerical result of our model for the normal restitution coefficient ϵ^N as a function of the normal relative velocity g^N compared to experimental data for the collision of spherical ice particles with an ice wall [33]. The experimental results are well reproduced by our model.

For the investigation of the tangential restitution coefficient of colliding homogeneous spheres ($J = \frac{2}{5} m R^2$, $\kappa = \frac{2}{7}$) we have chosen the Coulomb friction coefficient from the interval $\mu \in [10^{-2} \dots 1]$. The value of σ_*^T is a material constant. With Eq. (23) and the definitions of ξ_0 and η_* we estimate ζ_0 , which characterizes the size of the surface asperities via $\mu = \alpha \sqrt{\zeta_0}$. In the numerical calculation we have

chosen $\alpha = 1$. The results are shown in Fig. 2. The tangential restitution coefficient ϵ^T is drawn versus the plane defined by the tangential and normal velocities g^T and g^N . The three plots correspond to the values of the asperity sizes $\zeta_0 = (10^{-7}; 2 \times 10^{-4}; 10^{-3}) R^{\text{eff}}$, respectively.

The obvious common feature of all cases is sliding of the surfaces ($\epsilon^T > 0$) for small g^N and large g^T . This is quite plausible since smaller impact velocity g^N corresponds to a smaller normal acceleration and thus, to a smaller value of the maximal tangential force, Eq. (28). As a result $\epsilon^T \rightarrow 1$ at $g^N \rightarrow 0$ due to vanishing tangential acceleration. At the same time, for the high tangential velocity, $g^T(0) \gg 1$ [$g^N(0) \approx 1$], sliding occurs owing to a considerable breaking of the asperities. The area of the sliding phase in the g^N - g^T plane depends on the size ζ_0 of the asperities.

In the case of $\zeta_0 = 10^{-7} R^{\text{eff}}$ sliding occurs in the entire velocity range according to values $0.85 \leq \epsilon^T \leq 1$. The small asperities are not able to cause a sufficient torque to change

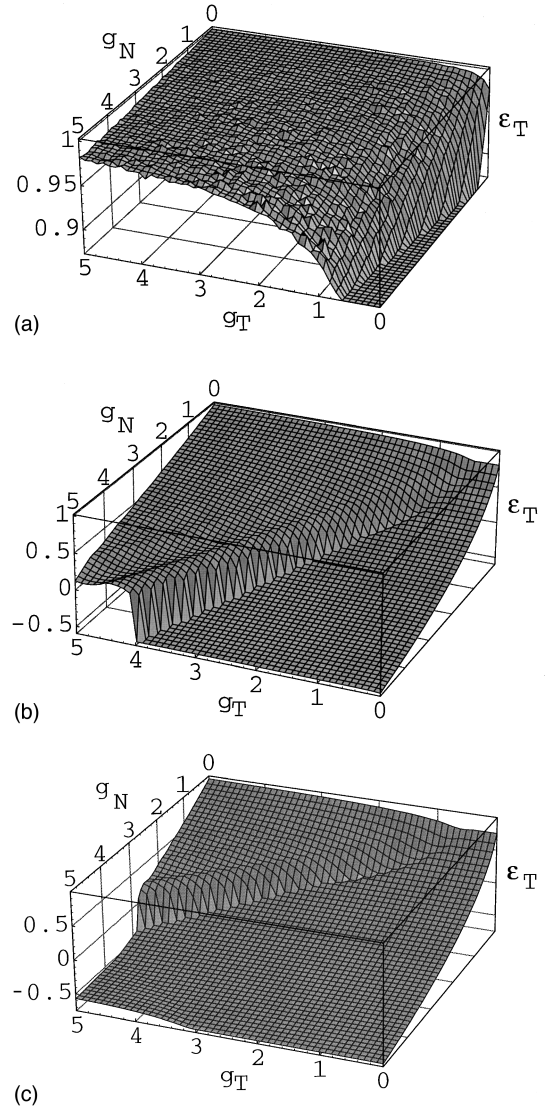

FIG. 2. The stereographic projection of the tangential restitution coefficient ϵ^T vs the plane g^N - g^T of the tangential and normal components of the impact velocity. The three parts of the figure belong to different values of the “size” of the asperities: (a) $\zeta_0 = 10^{-7} R^{\text{eff}}$, (b) $\zeta_0 = 2 \times 10^{-4} R^{\text{eff}}$, (c) $\zeta_0 = 10^{-3} R^{\text{eff}}$.

considerably the spin of the individual particles. Here we are close to the case of ideal smooth spheres where no change of the tangential motion is expected ($\epsilon^T = 1$).

In the other two cases $\zeta_0 = (2 \times 10^{-4}; 10^{-3})R^{\text{eff}}$ one recognizes two phases: (1) Sliding $\epsilon^T > 0$ at small g^N and high g^T ; (2) reversal of the spin of either particles $\epsilon^T < 0$ at small g^T and higher g^N .

Case (1) corresponds to the effect discussed in the context of $\zeta_0 = 10^{-7}$. Despite being far from rather smooth spheres, the small tangential force originated from small g^N changes the velocity g^T only slightly. Hence one has $\epsilon^T > 0$, which is also the case for high velocities g^T where the asperities break. In case (2) we have the other extreme: a high normal acceleration causes a tangential force, which is high enough to change the sign of g^T as long as the asperities do not break (small g^T). A complete reversal of the tangential velocity according to $g^T(0) \rightarrow -g^T(t_c)$ is not possible because of the dissipation arising of the bulk viscosity of the material, which enters the normal as well as the tangential forces [see Eqs. (18) and (30)].

Both types of behavior of the tangential motion are separated by a sharp transition at $g^T = g_{(\text{cr})}^T$ where the asperities begin to break [see surface plots for $\zeta_0 = (2 \times 10^{-4}; 10^{-3})R^{\text{eff}}$]. The higher g^N the larger the critical tangential velocity $g_{(\text{cr})}^T$. A higher normal velocity g^N causes a stronger counteracting force F^T and thus a larger tangential impact speed g^T is necessary to reach the critical deformation where the asperities break. Both cases [$\zeta_0 = (2 \times 10^{-4}; 10^{-3})R^{\text{eff}}$] reveal similar qualitative behav-

ior but the ranges of different types of motion [(1) and (2)] cover different areas in the g^T - g^N plane.

The results show that our model includes a continuous transition from the limit case of rough spheres ($\epsilon^T \rightarrow -1$) to the limit case of smooth spheres ($\epsilon^T \rightarrow 1$). In the literature of the dynamics of granular material an alternative step function is widely used for the tangential force [43]

$$F^T = \min\{-\gamma, m^{\text{eff}}|g^T|, \mu F^N\}. \quad (32)$$

The numerical evaluation of the considered model (Fig. 2) reveals surprising behavior of the tangential restitution coefficient ϵ^T as a function of the normal velocity g^N at fixed tangential velocity g^T . (This effect is noticeable for the largest values of ζ_0 .) At low and moderate g^N , ϵ^T first decreases with increasing g^N down to its minimal negative value in a manner discussed above, but when g^N exceeds some threshold (approximately of several g^T), it starts to increase up to zero at very high values of g^N . This effect may be explained as follows: For high values of g^N the average normal force is large and causes thus a large tangential force, which can effectively decelerate the initial tangential velocity without switching to the sliding regime.

Calculating the restitution coefficients ϵ^T , ϵ^N (in the limits of our model) we obtain a complete description of binary collisions. Therefore one can determine the dynamics for moderately dense granular gases, where an evolution occurs via a sequence of binary collisions. For such systems we have the following Boltzmann equation for the one-particle distribution function:

$$\left(\frac{\partial}{\partial t} + \vec{v}_1 \cdot \vec{\nabla}\right)f(1) = \int d\vec{v}_2 \int d\vec{\omega}_2 \int d\vec{n} |\vec{g} \cdot \vec{n}| \Theta(\vec{g} \cdot \vec{n}) \left[\frac{f(1')f(2')}{(\epsilon^N \epsilon^T)^2} - f(1)f(2) \right], \quad (33)$$

with $\Theta(x)$ given by

$$\Theta(x) = \begin{cases} 1 & \text{for } x \geq 0 \\ 0 & \text{for } x < 0 \end{cases} \quad (34)$$

and with the common notations, e.g., $(1) = \{\vec{r}_1, \vec{v}_1, \vec{\omega}_1, t\}$. The velocity and angular velocity of the first particle after the collision \vec{v}'_1 and $\vec{\omega}'_1$ can be expressed in terms of the precollisional values via the relations

$$\vec{v}'_1 = \vec{v}_1 + \frac{m^{\text{eff}}}{2m_1} \{ [\epsilon^T(g^N, g^T) - 1] \vec{g}^T - [\epsilon^N(g^N, g^T) + 1] \vec{g}^N \}, \quad (35a)$$

$$\vec{\omega}'_1 = \vec{\omega}_1 + \frac{m^{\text{eff}}}{2m_1} R \vec{n} \times \{ [\epsilon^T(g^N, g^T) - 1] \vec{g}^T - [\epsilon^N(g^N, g^T) + 1] \vec{g}^N \} \quad (35b)$$

and analogously for \vec{v}'_2 , $\vec{\omega}'_2$. With the use of Eqs. (33) and (35) and the above calculated restitution coefficients $\epsilon^N(g^N, g^T)$ and $\epsilon^T(g^N, g^T)$ [Eqs. (20) and (31)] one can describe the evolution of moderate dense granular gases with-

out computing the detailed dynamics of binary collisions as is usually done in the ‘‘soft sphere’’ molecular dynamics (MD) approach. Here one considers the grains as elastic bodies that deform each other during a collision. There are several *Ansätze* for the force acting between touching grains [43,44,58]. In all cases one has to choose a time step for the integration scheme that is significantly smaller than the typical collision time. Hence, during each collision one has to calculate about 10–1000 times the interaction force between the grains to provide satisfying accuracy of the simulation. When two grains approach each other they do not feel any interaction as long as they do not touch each other. When granular particles collide they interact via huge restoring forces that can be expressed by Young moduli of the order of $Y = 10^7$ kg/m sec². The difficulty of the simulation consists in the extreme short-range interaction of the particles and the resulting huge gradient of the interaction force. Therefore presently one cannot simulate much more than 3000 granular particles in three dimensions (e.g., [59,60]) and about 10^4 particles in two dimensions (e.g., [61]).

Another method for the simulation of granular assemblies is the ‘‘hard sphere’’ approach where one does not consider the details of the collision but only the precollisional and

postcollisional velocities of each pair of colliding grains. The advantage of these simulations is the low numerical complexity. One needs only computational effort when particles collide but not in between the collisions. This allows for the application of so-called event-driven calculations (e.g., [62]). Hence, one can simulate many more particles than with “soft particle” methods.

One of the preconditions for the application of the “hard sphere approach” is the exact knowledge of the normal and tangential restitution coefficients, ϵ^N and ϵ^T , as functions of the normal and tangential impact rates, \vec{g}^N and \vec{g}^T , whose theoretical determination was the goal of the present paper.

An interesting possible application of this approach is the dynamics of planetary rings composed of icy and silicate material, which is determined by inelastic dissipative collisions [38]. The calculation of such systems using the traditional MD is impossible due to the huge number of particles in these systems.

IV. CONCLUSION

A model for collision of particles in granular gases is proposed. For the normal component of the relative motion the equation of motion is derived based on the general consideration of the viscoelastic impact. We find the expression for the dissipative part of the normal force in the self-consistent quasistatic approximation that generalizes the existing results for the viscoelastic collisions [42]. For the tangential relative motion we investigated a mesoscopic model of surfaces of the colliding particles that are in contact. We found a mean-field expression for the tangential interparticle force, which can reproduce smooth, reflecting, or sticky collisions depending on the microscopic parameters of the surfaces and on the relative impact velocity. A frequently used model for collisions of granular particles by Haff and Werner [43] is contained in our model as a special case. The restitution coefficients for the normal and tangential motion are calculated as functions of the relative impact velocity. A rather nontrivial strongly nonlinear dependence of the tangential restitution coefficient on the impact velocity is observed.

The obtained restitution coefficients may be used to describe the dynamics of moderately dense granular gases, where the evolution occurs via a sequence of successive binary collisions.

ACKNOWLEDGMENTS

We thank H. J. Herrmann and J. T. Jenkins for discussion and S. Luding for critical remarks. One of us (N.V.B.) is very grateful to Professor J. Kurths for the warm hospitality in Potsdam.

APPENDIX A: GENERALIZATION OF THE HERTZ THEORY

We briefly sketch the Hertz theory of elastic impact and give a generalization of this theory for the case of viscoelastic collisions (see also [49]).

In the quasistatic approximation that is used in Hertz’s impact theory it is assumed that the (time dependent) strain and the (time dependent) stress are related in the same man-

ner as in the static case. It may be shown (see Appendix B) that this approximation is valid for the elastic case when the characteristic velocity is much less than the speed of sound in the material of the colliding particles. Moreover for the viscoelastic case it is required that the viscous relaxation time of the material is much shorter than the duration of the collision. In the static case the equation of equilibrium reads [48]

$$\vec{\nabla} \cdot \hat{\sigma}_{(\text{el})} = 0, \quad (\text{A1})$$

where the elastic stress tensor $\hat{\sigma}_{(\text{el})}$ is expressed in terms of displacements $\vec{u}(r)$ via Eq. (12). Hence the static Eq. (A1) can be written as

$$\vec{\nabla}_{\perp}^2 \vec{u} + b^2 \vec{\nabla}_{\parallel}^2 \vec{u} = 0, \quad (\text{A2})$$

$$b^2 = \frac{4E_1 + 6E_2}{3E_1} = \frac{2(1-\nu)}{(1-2\nu)},$$

with the “longitudinal” and “transversal” parts of the Laplacian

$$\vec{\nabla}_{\parallel}^2 = \vec{\nabla} \circ \vec{\nabla}, \quad (\text{A3a})$$

$$\vec{\nabla}_{\perp}^2 = \vec{\nabla}^2 - \vec{\nabla}_{\parallel}^2. \quad (\text{A3b})$$

The boundary conditions for the displacements in Eq. (A2) are formulated on the surface of contact. From geometric considerations it follows that the contact area between two colliding particles is a plane. Using the appropriate coordinate system centered in the middle of the contact region (where we set $z=0$) one can write

$$C_1 x^2 + C_2 y^2 + u_{z1} + u_{z2} = \xi. \quad (\text{A4})$$

The values $u_{z1} = u_{z1}(x, y)$ and $u_{z2} = u_{z2}(x, y)$ are the z components of the displacements in the materials of the bodies at the plane $z=0$, ξ is the total deformation (the sum of the deformations of both bodies at the center of the contact area, i.e., at $x=y=0$). The constants C_1 and C_2 are expressed in terms of radii of curvature of the surfaces in contact (see, e.g., [41,48]). The values of u_{z1} and u_{z2} may be expressed in terms of the normal pressure $P_z(x, y)$ that acts between the bodies at $z=0$ [48]:

$$u_{z1}(x, y, 0) = u_{z2} = \frac{\Lambda}{\pi} \int \int \frac{P_z(x', y')}{r} dx' dy',$$

$$r = \sqrt{(x-x')^2 + (y-y')^2}, \quad (\text{A5})$$

$$\Lambda = \frac{2E_1 + 3E_2}{E_1(E_1 + 6E_2)} = \frac{1-\nu^2}{Y}.$$

For simplicity we assume that the colliding particles are of the same material. The normal pressure P_z is related to the total normal force $F_{(\text{el})}$,

$$P_z(x, y) = \frac{3F_{(\text{el})}}{2\pi ab} \sqrt{1 - \frac{x^2}{a^2} - \frac{y^2}{b^2}}, \quad (\text{A6})$$

where a and b are the semiaxes of the contact ellipse. The latter values as well as the compression ξ may be found from the set of equations

$$\xi = \frac{F_{(\text{el})}}{\pi} \frac{3}{2} \Lambda \int_0^\infty \frac{dq}{\sqrt{(a^2+q)(b^2+q)q}}, \quad (\text{A7a})$$

$$C_1 = \frac{F_{(\text{el})}}{\pi} \frac{3}{2} \Lambda \int_0^\infty \frac{dq}{(a^2+q)\sqrt{(a^2+q)(b^2+q)q}}, \quad (\text{A7b})$$

$$C_2 = \frac{F_{(\text{el})}}{\pi} \frac{3}{2} \Lambda \int_0^\infty \frac{dq}{(b^2+q)\sqrt{(a^2+q)(b^2+q)q}}. \quad (\text{A7c})$$

From the above expressions it follows that for all bodies in contact having smooth surfaces (in the mathematical sense) the total force and the deformation are related via the power law

$$F_{(\text{el})}(\xi) = \tilde{c} \xi^{3/2}. \quad (\text{A8})$$

The constant \tilde{c} depends on the elastic properties of the materials and on the local curvatures of the colliding bodies. For the case of the spherical particles one has the Hertz's law

$$F_{(\text{el})}(\xi) = \frac{2Y}{3(1-\nu^2)} \sqrt{R^{\text{eff}} \xi^{3/2}}. \quad (\text{A9})$$

Using this relation between force and deformation and the equation of motion [Eq. (9)] one can describe the elastic collision completely. The duration of the collision is [41,48]

$$t_c = 2.94 \left(\frac{m^{\text{eff}}}{k} \right)^{2/5} (g^N)^{-1/5},$$

$$k^2 = \left(\frac{4}{5} \frac{2}{3\Lambda} \right)^2 R^{\text{eff}}. \quad (\text{A10})$$

In the solution of the elastic contact problem the displacement fields $\vec{u}_1(\vec{r})$ and $\vec{u}_2(\vec{r})$ are completely defined by the value of $F_{(\text{el})}$ and thus by the value of the deformation ξ . Hence we write $\vec{u}(\vec{r}) = \vec{u}(\vec{r}, \xi)$, i.e., the displacement field depends explicitly on the compression. Therefore we obtain for the velocity of the displacement in the quasistatic approximation

$$\dot{\vec{u}}(\vec{r}) = \dot{\xi} \frac{\partial}{\partial \xi} \vec{u}(\vec{r}, \xi) \quad (\text{A11})$$

and correspondingly for the dissipative part of the stress tensor

$$\sigma_{(\text{dis})}^{ik} = \dot{\xi} \frac{\partial}{\partial \xi} \left\{ \eta_1 u_{ik} + \left(\eta_2 - \frac{\eta_1}{3} \right) u_{ll} \delta_{ik} \right\}$$

$$= \dot{\xi} \frac{\partial}{\partial \xi} \sigma_{(\text{el})}^{ik} \quad (E_1 \leftrightarrow \eta_1, E_2 \leftrightarrow \eta_2). \quad (\text{A12})$$

We emphasize that the expression in the curly brackets in the above equation coincides with the elastic stress, provided the viscous constants are substituted by the elastic ones. The latter expression for the dissipative stress tensor is written for

the case when the memory effects in the viscous processes may be neglected. A more general case is discussed in Appendix B.

The $\sigma_{(\text{el})}^{zz}$ component of the elastic stress is equal to the normal pressure P_z at the plane $z=0$,

$$\sigma_{(\text{el})}^{zz}(x, y, 0) = E_1 \frac{\partial u_z}{\partial z} + \left(E_2 - \frac{E_1}{3} \right) \left(\frac{\partial u_x}{\partial x} + \frac{\partial u_y}{\partial y} + \frac{\partial u_z}{\partial z} \right)$$

$$= \frac{3F_{(\text{el})}}{2\pi ab} \sqrt{1 - \frac{x^2}{a^2} - \frac{y^2}{b^2}}. \quad (\text{A13})$$

With the transformation of the coordinate axes

$$x = \alpha x', \quad (\text{A14a})$$

$$y = \alpha y', \quad (\text{A14b})$$

$$z = z' \quad (\text{A14c})$$

and

$$\alpha = \left(\frac{\eta_2 - \frac{1}{3} \eta_1}{\eta_2 + \frac{2}{3} \eta_1} \right) \left(\frac{E_2 + \frac{2}{3} E_1}{E_2 - \frac{1}{3} E_1} \right), \quad (\text{A15a})$$

$$\beta = \frac{(\eta_2 - \frac{1}{3} \eta_1)}{\alpha(E_2 - \frac{1}{3} E_1)}, \quad (\text{A15b})$$

$$a = \alpha a', \quad (\text{A15c})$$

$$b = \alpha b', \quad (\text{A15d})$$

we obtain

$$\eta_1 \frac{\partial u_z}{\partial z} + \left(\eta_2 - \frac{\eta_1}{3} \right) \left(\frac{\partial u_x}{\partial x} + \frac{\partial u_y}{\partial y} + \frac{\partial u_z}{\partial z} \right)$$

$$= \beta \left[E_1 \frac{\partial u_z}{\partial z'} + \left(E_2 - \frac{E_1}{3} \right) \left(\frac{\partial u_x}{\partial x'} + \frac{\partial u_y}{\partial y'} + \frac{\partial u_z}{\partial z'} \right) \right]$$

$$= \beta \frac{3F_{(\text{el})}}{2\pi \alpha' b'} \sqrt{1 - \frac{x'^2}{a'^2} - \frac{y'^2}{b'^2}}$$

$$= \beta \alpha^2 \frac{3F_{(\text{el})}}{2\pi ab} \sqrt{1 - \frac{x^2}{a^2} - \frac{y^2}{b^2}}. \quad (\text{A16})$$

Applying the operator $\dot{\xi} \partial / \partial \xi$ to the previous expression we obtain the result for the viscous stress. Integrating the viscous stress over the contact area we finally find for the dissipative component of the interparticles force

$$F_{(\text{dis})} = A \dot{\xi} \frac{\partial}{\partial \xi} F_{(\text{el})}(\xi), \quad (\text{A17})$$

$$A = \alpha^2 \beta = \frac{1}{3} \frac{(3\eta_2 - \eta_1)^2 (1 - \nu^2)(1 - 2\nu)}{(3\eta_2 + 2\eta_1) Y \nu^2}. \quad (\text{A18})$$

Thus one obtains for the normal force that acts between the viscoelastic bodies in the quasistatic regime of collision

$$F = \text{const} \times \left(\xi^{3/2} + \frac{3}{2} A \sqrt{\xi} \dot{\xi} \right). \quad (\text{A19})$$

The constant in Eq. (A19) coincides with that for the elastic force. For colliding spherical particles we arrive at Eq. (17).

The impact theory, sketched above, was developed for bodies with smooth surfaces. If the surface asperities are taken into account, one can consider the actual surface as a smooth one (obtained by averaging over the asperities' heights), with a small perturbation superimposed due to the presence of the asperities. One can also consider the actual normal displacements and normal pressure as a sum of the averaged (over the asperities) values and the small perturbation. Then it is easy to show that the equations, obtained for the averaged values, coincide (due to linearity of the problem) with the corresponding equations for the elastic collision of the smooth bodies. As a result, the relation between the force and deformation (ξ is the same as in Hertz's theory) provided that ξ is defined with the use of the average over the asperities' radii of the colliders.

Considering the normal motion for the dissipative collisions, one need not consider the plastic deformation of the asperities, since the size of the asperities is assumed to be

very small compared with the radii of the spheres. For our calculations in Fig. 2 the asperity size is 10^3 – 10^7 times smaller than the effective radius of the particles. Hence the dissipation in the bulk of the asperities is negligibly small compared to the total dissipation in the compressed part of the collider. Moreover, the ratio of the normal to tangential stress may be roughly estimated as $\bar{\sigma}^N / \bar{\sigma}^T \sim (\xi/R)^{1/2}$, so that the crushing of the asperities does not seem to be important for the normal motion, if $\xi/R \ll 1$ and if the conditions of the quasistatic collision hold. Thus one concludes that the surface asperities may be ignored, when the normal motion is studied, provided they are small and the conditions of the quasistatic collision are satisfied.

APPENDIX B: VALIDITY OF THE QUASISTATIC APPROXIMATION

To analyze more rigorously the conditions when the quasistatic approximation is valid we write the equation of motion for the viscoelastic continuum

$$\rho \ddot{\mathbf{u}} = \nabla \cdot (\hat{\sigma}_{(\text{el})} + \hat{\sigma}_{(\text{dis})}), \quad (\text{B1})$$

where ρ is the density of the material. The expression for the elastic part of the stress tensor is given by Eq. (12). Taking into account the memory effects of the dissipative processes in the material one can write for the dissipative part

$$\hat{\sigma}_{(\text{dis})}(t) = E_1 \int_0^t d\tau \psi_1(t-\tau) \left[\frac{1}{2} \left\{ \nabla \circ \dot{\mathbf{u}}(\tau) + 32 \dot{\mathbf{u}}(\tau) \circ \nabla \right\} - \frac{1}{3} \hat{\mathbf{I}} \nabla \cdot \dot{\mathbf{u}}(\tau) \right] + E_2 \int_0^t d\tau \psi_2(t-\tau) \hat{\mathbf{I}} \nabla \cdot \dot{\mathbf{u}}(\tau), \quad (\text{B2})$$

where the (dimensionless) functions $\psi_1(t)$ and $\psi_2(t)$ are relaxation (or “memory”) functions for the distortion strain and the dilatation, respectively. Note that Eq. (B2) coincides with the corresponding expression for the viscous stress tensor in [34,42] for $\psi_2(t) = 0$. The latter approximation means that one neglects the bulk dissipation due to the dilatation rate. For the normal motion of colliding particles, however, the dissipation of energy due to the dilatation rate and the dissipation due to the distortion strain rate are of the same order of magnitude. Thus we keep both relaxation functions in our considerations. Introducing transversal and longitudinal velocities of sound in the material

$$c_t^2 = \frac{E_1}{2\rho} = \frac{Y}{2\rho(1+\nu)}, \quad (\text{B3a})$$

$$c_l^2 = \frac{2E_1 + 3E_2}{3\rho} = \frac{Y(1-\nu)}{\rho(1+\nu)(1-2\nu)}, \quad (\text{B3b})$$

$$b^2 = \frac{c_t^2}{c_l^2} = \frac{2(1-\nu)}{(1-2\nu)},$$

one can write the equation of motion for the viscoelastic medium:

$$\frac{1}{c_t^2} \ddot{\mathbf{u}} = \{ \nabla_{\perp}^2 \dot{\mathbf{u}} + b^2 \nabla_{\parallel}^2 \dot{\mathbf{u}} \} + \nabla_{\perp}^2 \psi_1 * \dot{\mathbf{u}} + \nabla_{\parallel}^2 \left\{ \frac{4}{3} \psi_1^* \dot{\mathbf{u}} + \left(b^2 - \frac{4}{3} \right) \psi_2 * \dot{\mathbf{u}} \right\}, \quad (\text{B4})$$

where $\psi * \dot{\mathbf{u}}$ denotes convolution.

To estimate the relative importance of the terms in Eq. (B4) we introduce the characteristic velocity $v_0 = g^N$ and the characteristic time $\tau_0 = t_c$, where t_c is the duration of the collision, introduced above in Eq. (A10). Then the characteristic length is $R_0 = v_0 \tau_0$. Equation (B4) can then be written in a dimensionless form:

$$\left(\frac{v_0^2}{c_t^2}\right) \dot{\tilde{u}}(t) = \{\bar{\nabla}_\perp^2 \tilde{u}(t) + b^2 \bar{\nabla}_\parallel^2 \tilde{u}(t)\} + \left(\frac{\tau_{\text{vis},1}}{\tau_0}\right) \bar{\nabla}_\perp^2 \dot{\tilde{u}}(\tilde{t}_*) + \left(\frac{\tau_{\text{vis},1}}{\tau_0}\right) \bar{\nabla}_\parallel^2 \left\{ \frac{4}{3} \dot{\tilde{u}}(\tilde{t}_*) + \left(b^2 - \frac{4}{3}\right) \left(\frac{\tau_{\text{vis},2}}{\tau_{\text{vis},1}}\right) \dot{\tilde{u}}(\tilde{t}_*) \right\}, \quad (\text{B5})$$

$$\tau_{\text{vis},1/2} = \int_0^t \psi_{1/2}(\tau) d\tau. \quad (\text{B6})$$

We use the following representation of the convolution:

$$\psi * \dot{\tilde{u}} = \dot{\tilde{u}}(\tilde{t}_*) \int_0^t \psi_{1/2}(\tau) d\tau, \quad (\text{B7})$$

with \tilde{t}_* being a dimensionless time from the interval $0 \leq \tilde{t}_* \leq \tilde{t} = t/\tau_0$. The relation for the convolution (B7) is valid if $\psi(t) \geq 0$.

During the collision process t is of the order of τ_0 ; i.e. \tilde{t} is of the order of 1, while by the definition of $\tau_{\text{vis},1/2}$ these values are of the order of the relaxation times for the dissipative processes in the material. That means that $\tau_{\text{vis},1/2}$ characterizes the time when the memory effects are important. If the duration of the collision is much greater than the relaxation times, i.e., if $\tau_{\text{vis},1/2} \ll \tau_0$, one can write

$$\tau_{\text{vis},1/2} \approx \int_0^\infty \psi_{1/2}(\tau) d\tau \quad (\text{B8})$$

and consequently

$$\psi * \dot{\tilde{u}} \approx \dot{\tilde{u}}(t) \tau_{\text{vis},1/2}. \quad (\text{B9})$$

If the characteristic velocity v_0 is much less than the speed of sound in the material too, one can neglect the terms with vanishing factors (v_0^2/c_t^2) and $(\tau_{\text{vis},1/2}/\tau_0)$ in Eq. (B5) and finally one arrives at the static Eq. (A2). That means the quasistatic approach is valid provided that the conditions

$$1 \gg \frac{v_0^2}{c_t^2}, \quad (\text{B10a})$$

$$1 \gg \frac{\tau_{\text{vis},1/2}}{\tau_0} \quad (\text{B10b})$$

hold. From the above considerations it follows that in the quasistatic approximation the memory effects in the dissipative processes are not important and the viscous part of the stress tensor may be written in the same way as in Eq. (12), with the viscous constants η_1 and η_2 given by

$$\eta_{1/2} = E_{1/2} \tau_{\text{vis},1/2} = E_{1/2} \int_0^\infty \psi_{1/2}(\tau) d\tau. \quad (\text{B11})$$

It is worth noting that the quasistatic approximation is valid for many of the granular gases one encounters in nature, since usually the characteristic velocity in these systems is low. One should also note that the description of the collision in the quasistatic approximation is rigorous in a sense that no other additional approximations are used.

As follows from the above considerations, it is not correct to use the time dependent relaxation functions for the dissipative part of the stress tensor together with Hertz's quasistatic relations [34,42], since this approach is not self-consistent and one has to assume a lot of additional hardly controllable approximations.

-
- [1] C. S. Campbell, *Annu. Rev. Fluid Mech.* **22**, 57 (1990).
[2] P. A. Thompson and G. S. Grest, *Phys. Rev. Lett.* **67**, 1751 (1991).
[3] T. G. Drake, *J. Geophys. Res.* **95**, 8681 (1990); *J. Fluid Mech.* **199**, 177 (1989); **225**, 121 (1991).
[4] Hagen, *Verhandl. Königl. Preuss. Akad.* **35** (1852).
[5] K. L. Schick and A. A. Verveen, *Nature* **251**, 599 (1974).
[6] P. Evesque and J. Rajchenbach, *Phys. Rev. Lett.* **62**, 44 (1989).
[7] F. Dinkelacker, A. Hübler, and E. Lüscher, *Biol. Cybern.* **56**, 51 (1987).
[8] G. W. Baxter, R. P. Behringer, T. Fagert, and G. A. Johnson, *Phys. Rev. Lett.* **62**, 2825 (1989); *J. Fluid Mech.* **199**, 177 (1989); **225**, 121 (1991).
[9] C-h. Liu and S. R. Nagel, *Phys. Rev. Lett.* **68**, 2301 (1992).
[10] H. M. Jaeger and S. R. Nagel, *Science* **255**, 1523 (1992).
[11] J. T. Jenkins, in *Non-classical Continuum Mechanics*, edited by R. J. Knops and A. A. Lacey (Cambridge University Press, Cambridge, 1987).
[12] S. F. Edwards and R. B. S. Oakeshott, *Physica A* **157**, 1080 (1989); S. F. Edwards, *J. Stat. Phys.* **62**, 889 (1991).
[13] H. J. Herrmann, *J. Phys. (Paris)* **3**, 427 (1993).
[14] *Granular Matter*, edited by A. Mehta (Springer, New York, 1993).
[15] T. Riethmüller, L. Schimansky-Geier, D. Rosenkranz, and T. Pöschel (unpublished).
[16] P. Bak, C. Tang, and K. Wiesenfeld, *Phys. Rev. Lett.* **59**, 381 (1987).
[17] G. W. Baxter and R. P. Behringer, *Physica D* **51**, 465 (1991); *Phys. Rev. A* **42**, 1017 (1990).
[18] H. Puhl, *Physica A* **182**, 295 (1992).
[19] P. Devillard, *J. Phys. (Paris)* **51**, 369 (1990).
[20] G. Peng and H. J. Herrmann, *Phys. Rev. E* **49**, R1796 (1994).
[21] Y. H. Taguchi, *Phys. Rev. Lett.* **69**, 1387 (1992).
[22] J. A. C. Gallas, H. J. Herrmann, and S. Sokołowski, *Phys. Rev. Lett.* **69**, 1371 (1992).
[23] H. J. Herrmann, *Physica A* **191**, 263 (1992).
[24] T. Pöschel and V. Buchholtz, *Phys. Rev. Lett.* **71**, 3963 (1993).
[25] Y. Tsuji, T. Tanaka, and T. Ishida, *Powder Technol.* **71**, 239

- (1992).
- [26] O. Walton (unpublished).
- [27] J. A. C. Gallas, H. J. Herrmann, T. Pöschel, and S. Sokołowski (unpublished).
- [28] W. M. Visscher and M. Bolsterli, *Nature* **239**, 504 (1972).
- [29] R. Jullien, P. Meakin, and A. Pavlovitch, *Phys. Rev. Lett.* **69**, 640 (1992).
- [30] I. Goldhirsch and G. Zanetti, *Phys. Rev. Lett.* **70**, 1619 (1993).
- [31] G. Baumann, I. M. Jánosi, and D. E. Wolf, *Europhys. Lett.* **27**, 203 (1994).
- [32] S. F. Foerster, M. Y. Louge, H. Chang, and Kh. Allia, *Phys. Fluids* **6**, 1108 (1994).
- [33] F. G. Bridges, A. Hatzes, and D. N. C. Lin, *Nature* **309**, 333 (1984).
- [34] W. Goldsmith, *Impact* (Edward Arnold Ltd., London, 1960).
- [35] C. K. K. Lun and S. B. Savage, *Acta Mechanica* **63**, 15 (1986).
- [36] S. Araki and S. Tremaine, *Icarus* **65**, 83 (1986).
- [37] J. Wisdom and S. Tremaine, *Astron. J.* **95**, 925 (1988).
- [38] R. Greenberg and A. Brahic, *Planetary Rings* (Univ. of Arizona Press, Tucson, 1984).
- [39] K. L. Johnson, *Contact Mechanics* (Cambridge University Press, Cambridge, 1985).
- [40] F. Spahn, J.-M. Hertzsch, and N. V. Brilliantov, *Chaos, Solitons & Fractals* **5**, 1945 (1995).
- [41] H. Hertz, *J. Reine angewandte Phys.* **92**, 156 (1882).
- [42] Y. H. Pao, *J. Appl. Phys.* **26**, 1083 (1955).
- [43] P. Cundall and O. D. L. Strack, *Géotechnique* **29**, 47 (1979).
- [44] P. K. Haff and B. T. Werner, *Powder Technol.* **48**, 239 (1986).
- [45] J. P. Dilley, *Icarus* **105**, 225 (1993).
- [46] T. Pöschl, *Z. Phys.* **46**, 142 (1928).
- [47] P. Goldreich and S. Tremaine, *Icarus* **34**, 227 (1978).
- [48] L. D. Landau and E. M. Lifschitz, *Theory of Elasticity* (Oxford University Press, Oxford, 1965).
- [49] J.-M. Hertzsch, F. Spahn, and N. V. Brilliantov, *J. Phys. (France) II* **5**, 1725 (1995).
- [50] H. Czichos, *Tribology* (Elsevier, Amsterdam, 1978).
- [51] T. Pöschel and H. J. Herrmann, *Physica A*, **198**, 441 (1993).
- [52] J. A. Greenwood and J. B. P. Williamson, *Proc. Roy. Soc. London A* **295**, 300 (1966).
- [53] C. A. Coulomb, *Acad. R. Sci. Mem. Math. Phys. par Divers Savants* **7**, 343 (1773).
- [54] R. Burridge and L. Knopoff, *Bull. Seismol. Soc.* **57**, 341 (1967).
- [55] J. M. Carlson and J. S. Langer, *Phys. Rev. Lett.* **62**, 2632 (1989); *Phys. Rev. A* **40**, 6470 (1989).
- [56] W. H. Press, B. P. Flannery, S. A. Teukolsky, and W. T. Vetterling, *Numerical Recipes* (Cambridge University Press, Cambridge, 1987).
- [57] *Physical Properties of Rocks*, edited by K.-H. Hellwege and O. Madelung, Landolt-Börnstein, New Series, Group V, Vol. 1, Pt. a (Springer, Berlin, 1982).
- [58] O. R. Walton, in *Numerical Methods in Geomechanics*, edited by Z. Eisenstein (Balkema, Rotterdam, 1982), p. 1261.
- [59] O. R. Walton (unpublished).
- [60] J. A. C. Gallas, H. J. Herrmann, T. Pöschel, and S. Sokołowski, *J. Stat. Phys.* (to be published).
- [61] T. Pöschel and V. Buchholtz, *Chaos, Solitons and Fractals* **5**, 1 (1995).
- [62] D. C. Rapaport, *J. Comput. Phys.* **34**, 184 (1980).